

MTT-S 2009 MicroApps

Measuring Amplifier Large Signal Noise Figure via Phase Noise

authors:

Jason Breitbarth, PhD.

Miloš Janković



Boulder, Colorado, USA

www.holzworth.com

Presentation Outline

- Noise Figure (NF) – What is it?
- Y-Factor NF Measurement
- Additive (Residual) Phase Noise Measurement
- Noise Figure Relating to Phase Noise
- Amplifiers in High Compression
- Large Signal NF and Oscillator Design
- Summary

Noise Figure

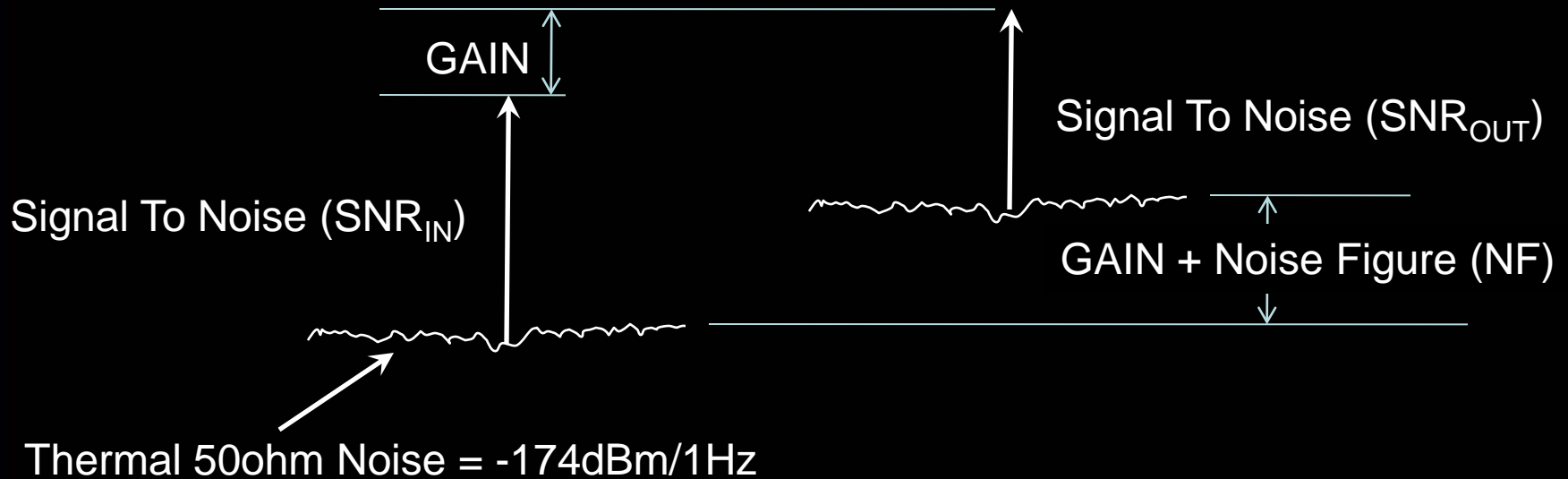

$$NF = SNR_{IN} - SNR_{OUT}$$

Y-Factor (Hot, Cold)

- Y-Factor measures in true small signal and mimics a receiver
- Easy Measurement, well accepted in industry.
- Y-Factor has no meaning in large signal!
- Only valid for class-A or AB type amplifiers with appropriate bias.
- High-Efficiency amplifiers CANNOT be measured.
- Y-Factor is a 4MHz AVERAGE of noise and gives no information close to the carrier.

Additive Phase Noise with an *'Ideal'* Spectrum Analyzer

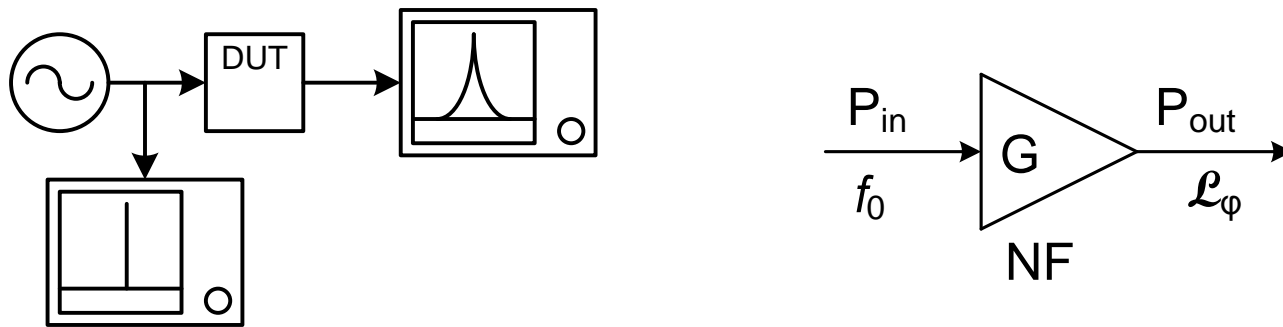

Ideal Spectrum Analyzers Don't Exist!

How do we measure Noise?

Additive Phase Noise Measurement (Discriminator)

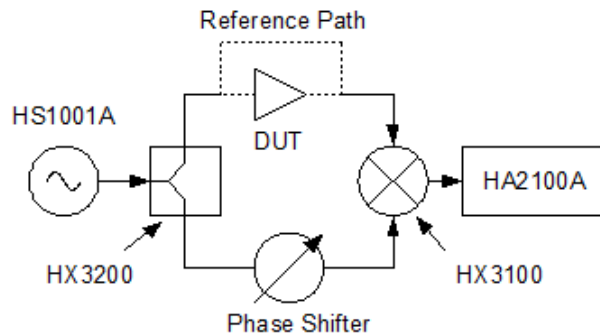

$$\mathcal{L}_\phi [dBc / Hz]$$

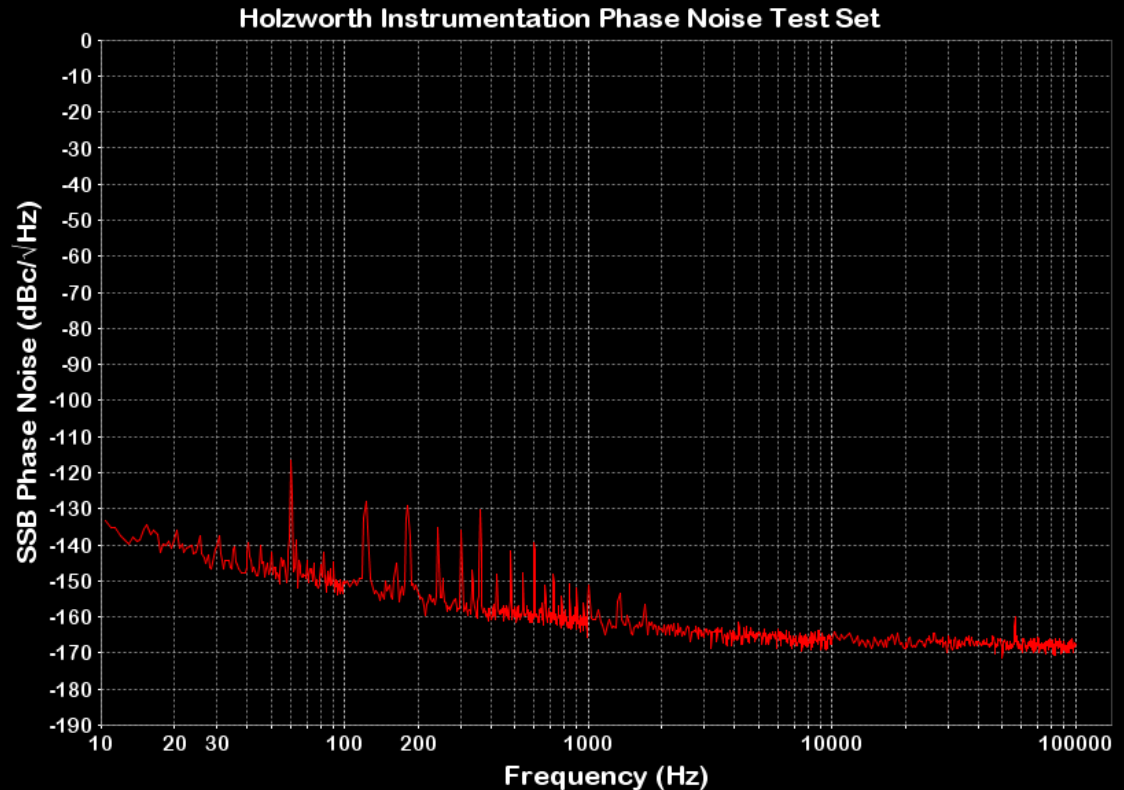

Phase Noise to Noise Figure

$$\mathcal{L}_\phi [dBc / Hz] = SNR_{OUT} (dBc)$$

$$SNR_{OUT} (dBc) = \underbrace{-177 dBm - P_{IN} (dBm)}_{SNR_{IN} (dBc)} + NF_{DUT} (dB)$$

$$NF_{DUT} = SNR_{OUT} - SNR_{IN}$$

Large Signal NF Measurements

$P_{in} = 26\text{dBm}$

$$NF(1\text{k}) = 64\text{dB} = -139\text{dBc} - (-177\text{dBm} - 26\text{dBm})$$

$$NF(100\text{k}) = 41\text{dB} = -162\text{dBc} - (-177\text{dBm} - 26\text{dBm})$$

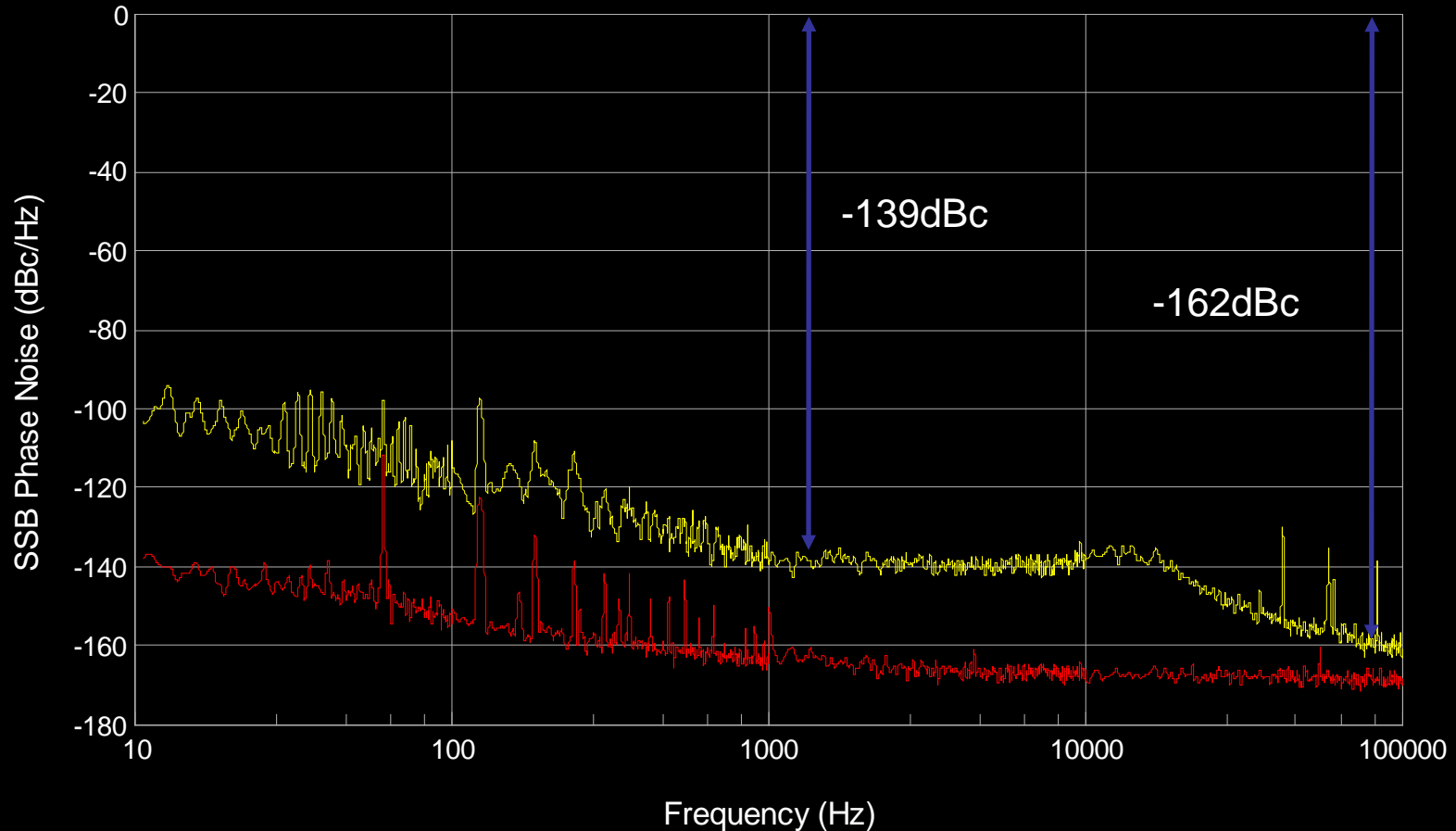

Noise Figure vs. Power Input

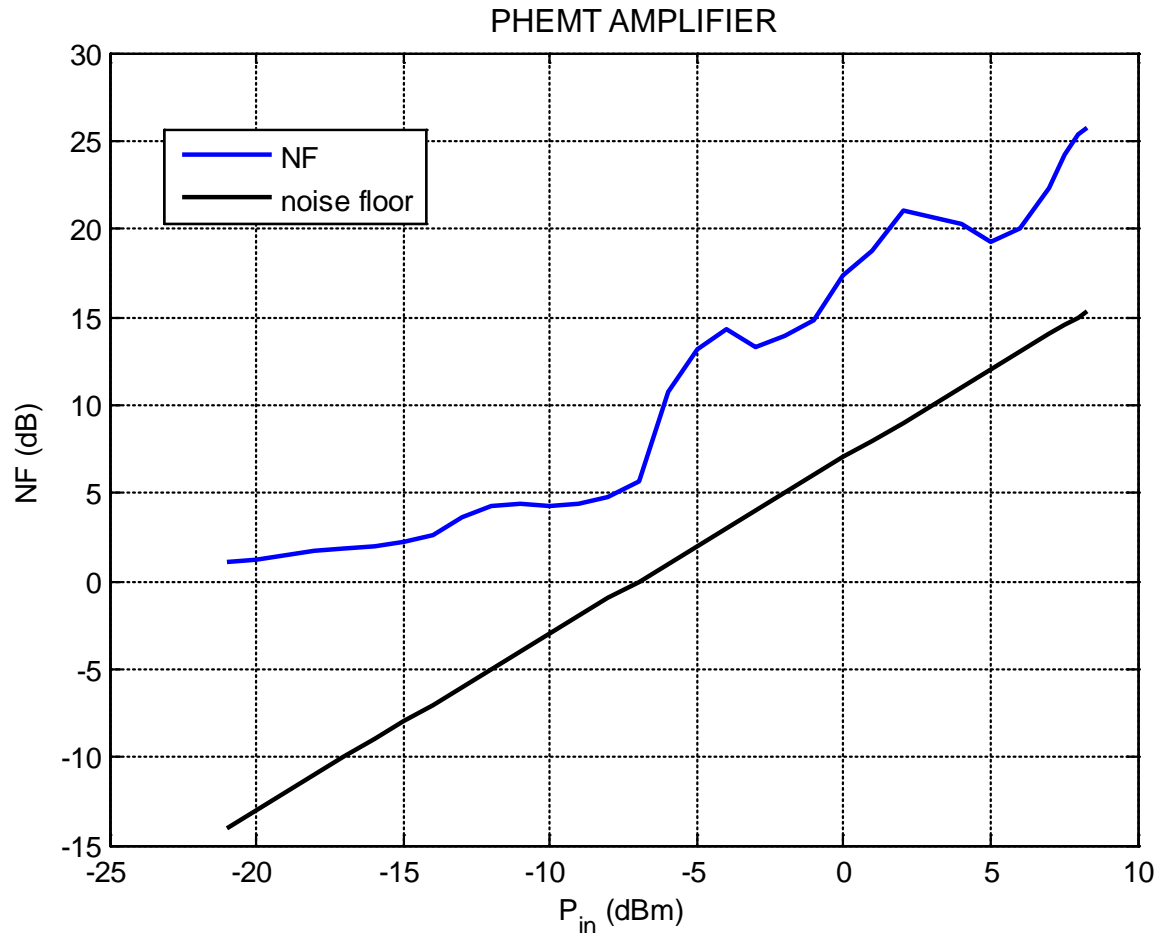

Noise Figure vs. Load Pull

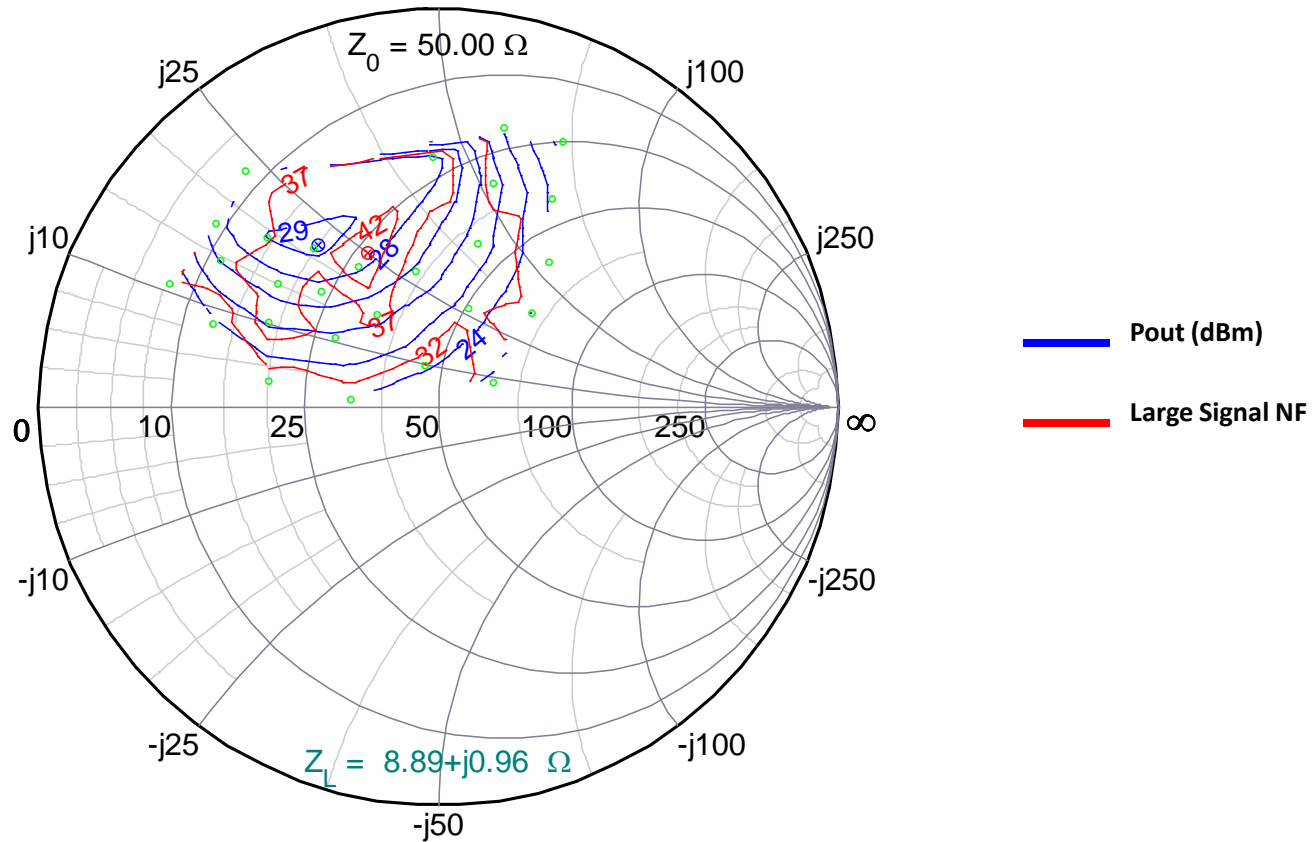

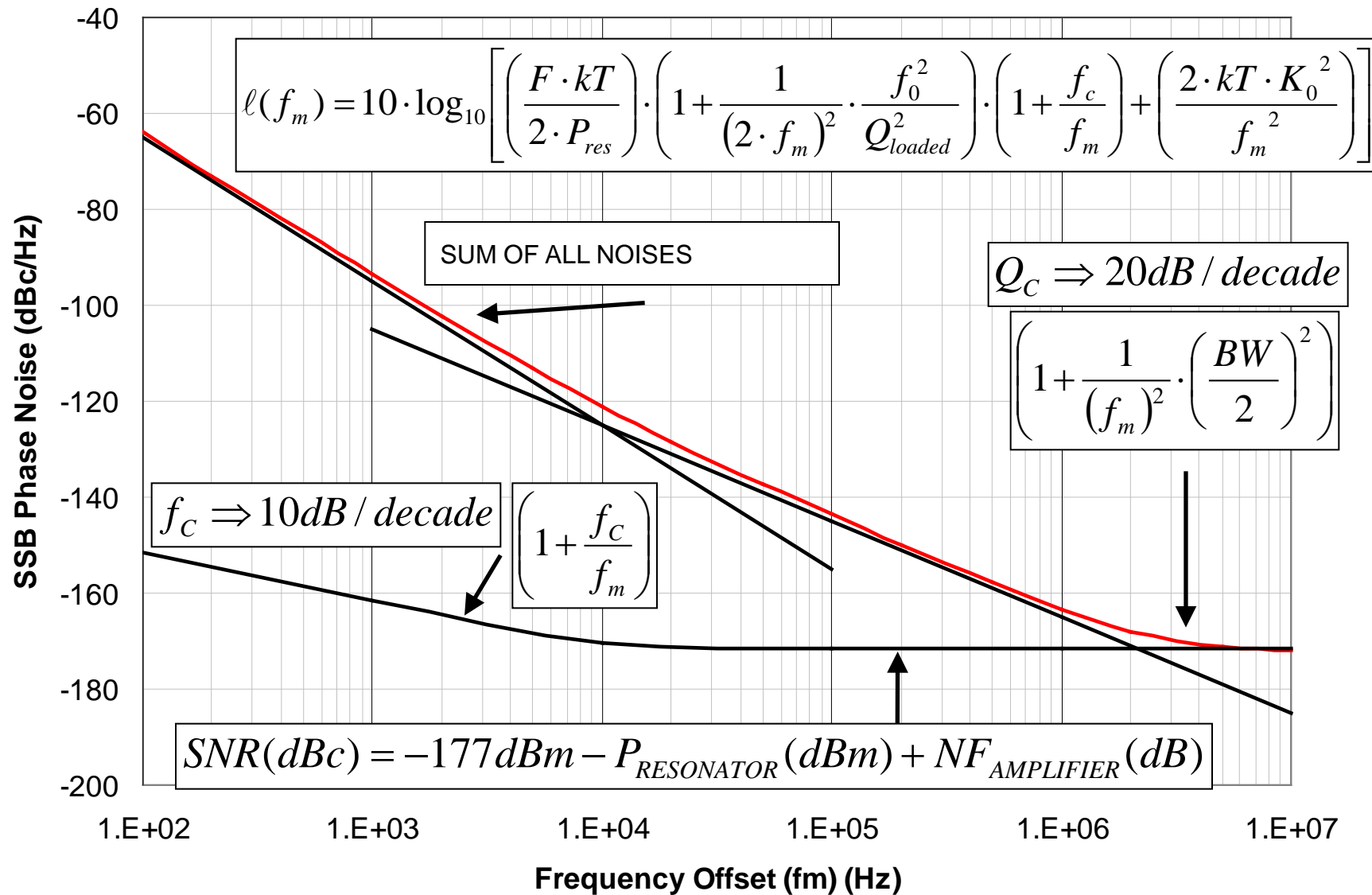

BJTs for 3.4GHz Low Power Oscillator

Data Sheet Noise Figure:
-BFP 405: 1.2 dB
-BFP 420: 1.15dB
-NE894M13: 1.4 dB

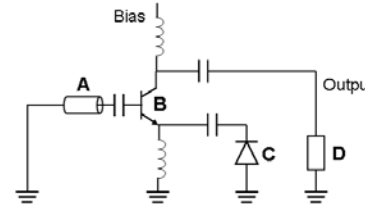

Standard Bias

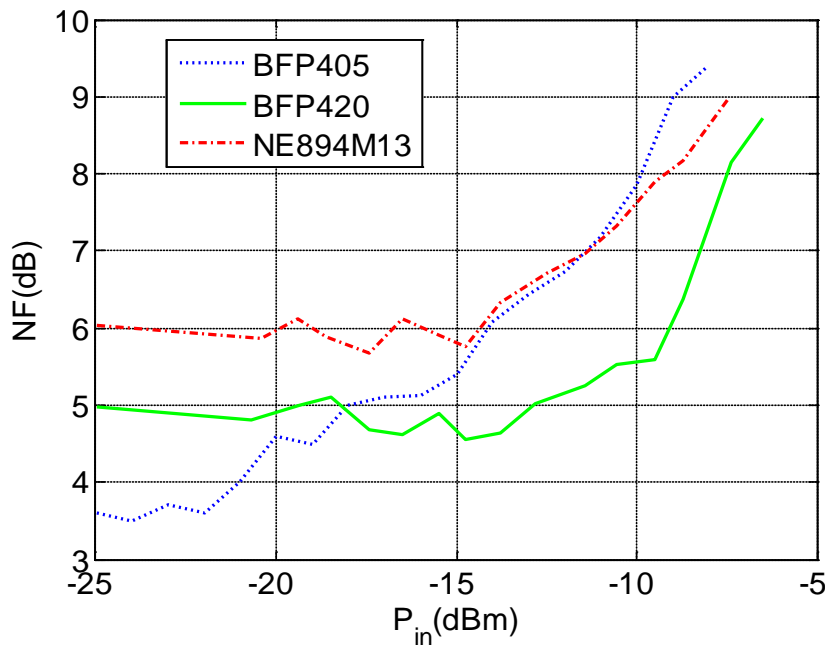

3dB Compression

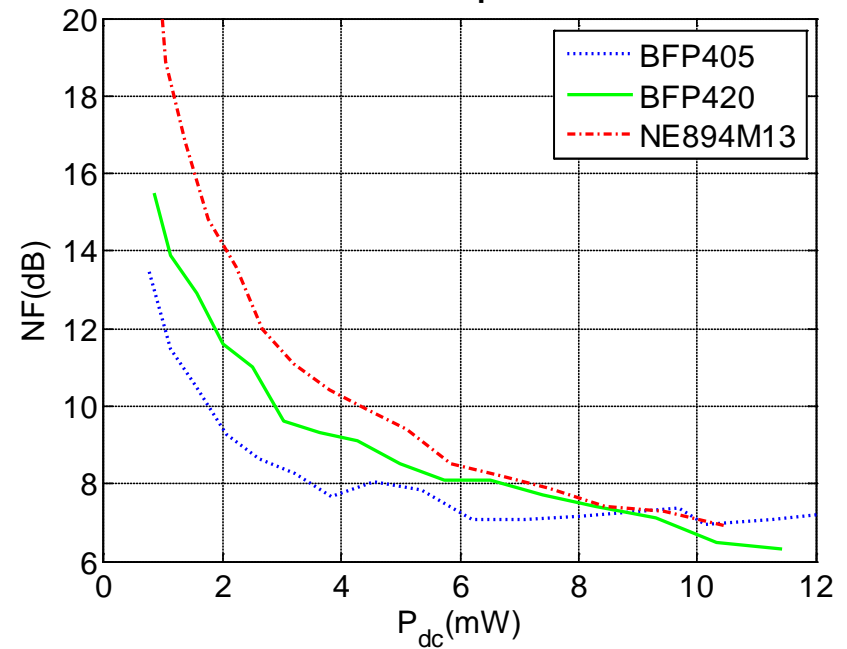

Noise Figure Measurement Summary

- Y-Factor Method only for Class-A Amplifiers
- Low Noise Figure does NOT Equal Low Phase Noise
- Large Signal Noise Figure is the NF for Leeson's Equation
- NF is a function of Offset Frequency

THANK YOU

Contact Information:

Jason Breitbarth, PhD

jason@holzworth.com

Phone: +1.303.325.3473

MTT Exhibition Booth No. : 504



Boulder, Colorado, USA

www.holzworth.com

